

The best remodel designs start with accurate room measurements. Whether you are doing it yourself or working with a professional, the success of your new space starts with a detailed floorplan and dimensions. Ask your designer about professional measurement options, this helps ensure the most accurate dimensions for your space.

Please read ALL of these instructions carefully from start to finish before beginning to measure your space.

For more information, visit:
www.woodmarkcabinetry.com

There's a lot to account for before your designer can start creating your new favorite room.

To help save time and confusion, we've created this guide to walk you through five easy steps to create drawings and provide the information necessary for your designer to start the process.

- 1 Floor Plan Drawing page 4**
A birds-eye view of your space
- 2 Wall Elevation Drawings page 5**
A vertical and horizontal map of each wall, from a straight on view
- 3 Construction Details page 6**
Important information for your renovation project
- 4 Appliances page 6**
Dimensions and manufacturers specs for your appliances
- 5 Photography page 6**
Photos of your space before renovation

Before we get started, make sure you have the following supplies below:

- Printed copy of our Measurement Guide for reference and graph paper
- Helper: having an extra hand is ideal for helping hold the tape measure level
- 25' Tape Measure (Metal)
- Pencil and Highlighter
- Ladder or Stepstool

IMPORTANT NOTES ABOUT MEASURING FOR YOUR REMODEL

Always Measure In Inches

Cabinets and appliances are measured in inches, so your floorplan dimensions should be recorded in inches, not feet and inches.

For example, 11' 6 1/8" should be recorded as 138 1/8" on your floorplan.

NOTE:

- **When measuring ceilings, walls and openings, round down to the nearest 1/8"**
Example: 138 3/16" should be recorded as 138 1/8" on your floorplan
- **When measuring appliances, round up to the nearest inch**
Example: 35 11/16" should be recorded as 36" on your floorplan

Recording Your Measurements

We've provided graph paper to help with your final drawings. It is much more important to record accurate dimensions, rather than draw your room to scale. Be sure to write the actual dimensions on your drawings for all the elements in your space.

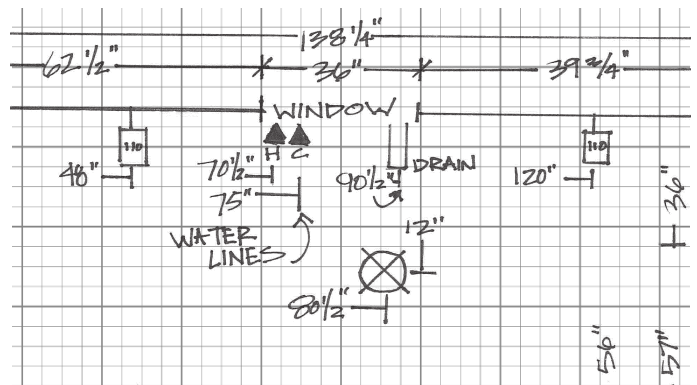

MEASURING TIPS

Use Metal Tape Measures Only

Cloth or plastic tape measures may stretch, causing errors in measurements. Using a standard 25' metal tape measure allows for the most accurate dimensions.

Standard US construction materials are measured in inches. Use a US tape measure and record your dimensions in inches, not feet and inches.

NOTE:

You do not need to measure closer than $\frac{1}{8}$ "

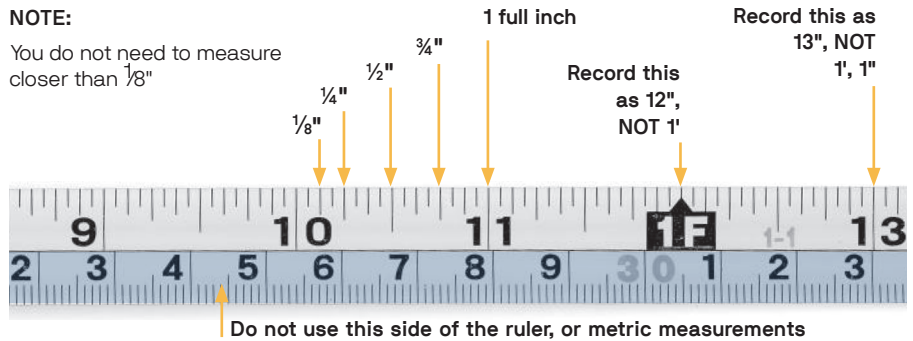

Universal Floorplan Symbols

The symbols below can help your designer better understand your floorplan dimensions, openings and obstructions.

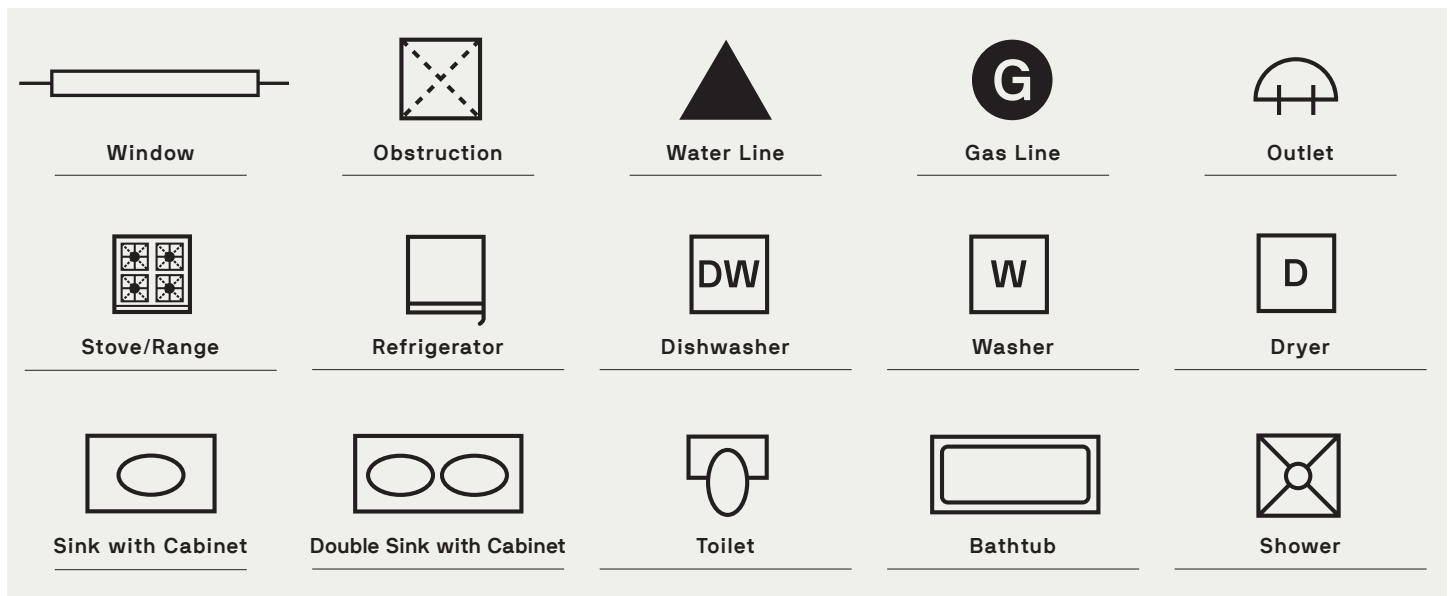

Measuring openings, windows, outlets and plumbing can be tricky. Below are some tips for how to properly measure your space and record the information for your floorplan and elevation drawings.

Remember, always double-check your measurements, this can save time in the long run and avoid costly mistakes!

Measuring Doors, Windows and Openings

Your designer needs to know the exact size of all doors, windows and openings, including trim in order to plan your new space. Below are some tips for getting the most accurate measurements.

Record all measurements below:

- A. Width, including trim
- B. Height, including trim
- C. Distance from floor to bottom of the trim
- D. Distance from floor to top of window trim
- E. Width of windowsill

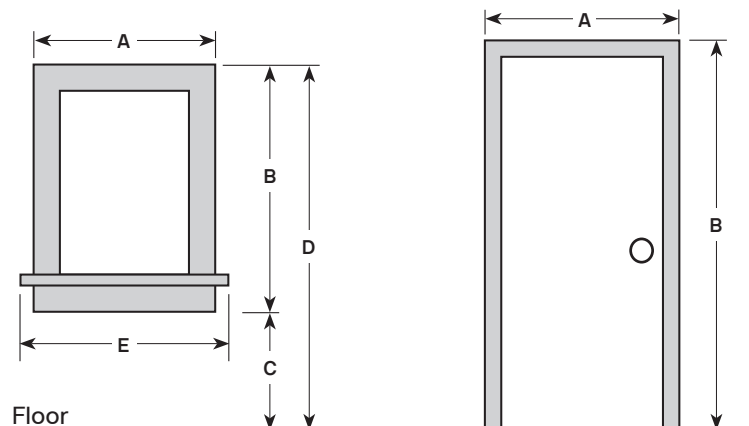

Locating Doors, Windows And Openings

The exact location of all doors, windows and openings is important for your designer to start your layout. Measure from the wall to the outside edge of the trim for accurate measurements.

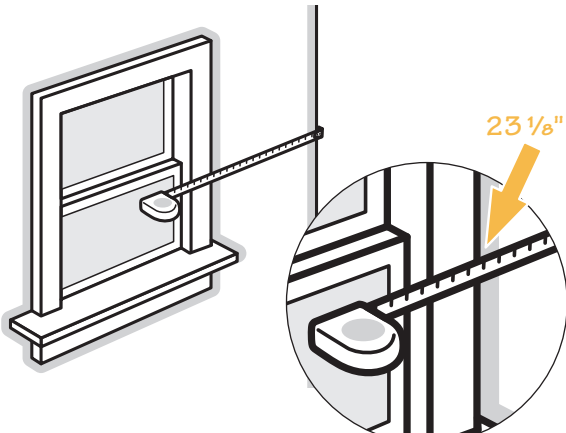

Round down to the nearest $\frac{1}{8}$ " , and write it on your drawings.

Range hoods

If you have an existing range hood vent or over the range wall microwave, note the location on your drawing. Specify if it exhausts back into the room, or if it has ducts that vent to outside. If the hood vents to the outside, note if it vents through the wall or the ceiling.

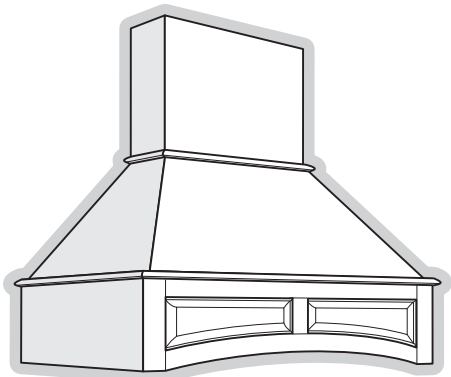

Locate outlets and switches

Measure outlets and switches horizontally and vertically to the center of the wall plate as shown. Be sure to label the difference between any 110- and 220-volt outlets

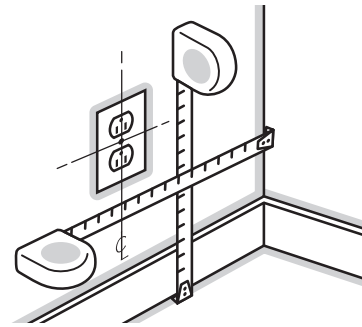

Locate water and utility lines

Mark the center line location for any sinks, drains, water or gas lines and any heading or air conditioning vents as shown.

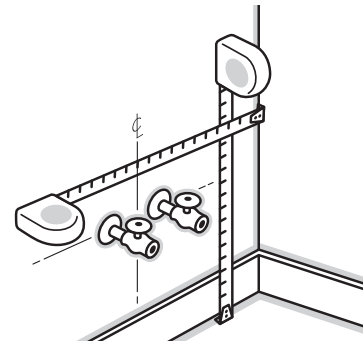

Placing Appliances and Utilities

Identify all large appliances, fixtures, furniture, and anything else you plan to keep after laying out your new space. Utilities to include:

- **Water/Gas Lines**
(Refrigerators, Sinks, Dishwashers, Pot Fillers, Stoves, Drains, etc.)
- **Electrical Outlets**
(standard 110 and 220 amps should be noted)
- **Heating or Air Vents**
- **Light Switches**
- **Range Hoods**
(note if this exhausts into the room or ducts to vent outside)

IMPORTANT!

Be sure to write the measurements on your drawings!

Most grid paper is to scale, but your designer won't know what size your space is unless you write down the dimensions.

1 CREATING A FLOOR PLAN DRAWING

A Floor Plan is a "bird's eye" view of the whole room, showing all four walls and the location of important utilities.

Start with your wall drawings

Start your Floor Plan with Wall A, the sink wall. Then go clockwise around the room with walls B, C, and D. Mark the locations of openings and fixtures along the wall segments.

Locate ceiling lights and other fixtures

Measure in two directions to locate the center of ceiling lights, fans, air vents, and any other fixtures in the floor or ceiling.

Locate islands and peninsulas

If there is an existing island or peninsula, mark its size and location. Mark any outlets or utilities coming to these structures.

Always double-check your measurements!

The total of your wall segments must equal your overall wall length.

$$\text{Example: } 62\frac{1}{2}'' + 36'' + 39\frac{3}{4}'' = 138\frac{1}{4}''$$

Transfer measurements to grid

Transfer all of your measurements to the grid pages in this guide following the example below.

It is more important to write down the exact measurements than to draw the floor plan to scale.

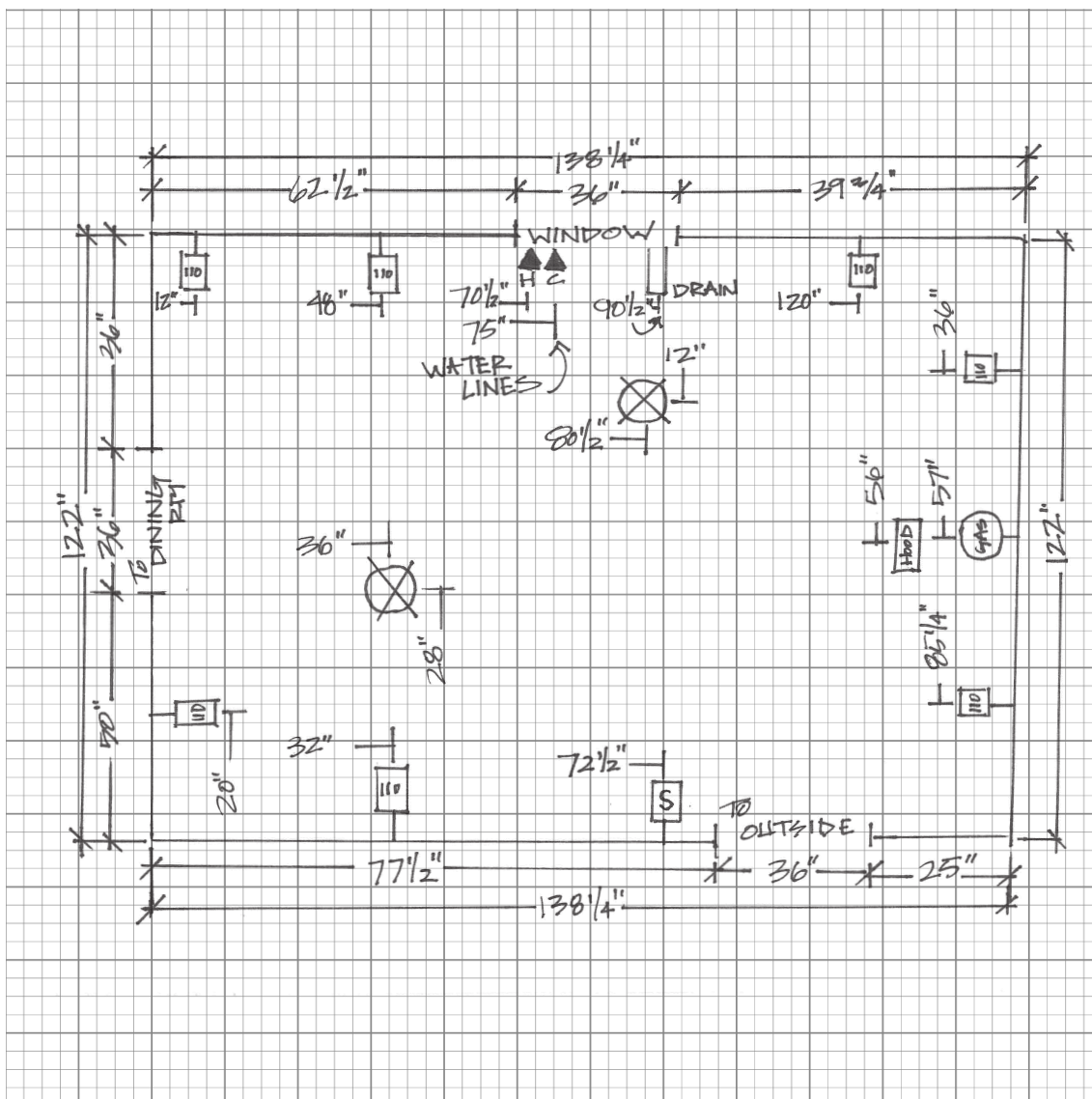

Scale: 3/4" = 1'

2 CREATING WALL ELEVATION DRAWINGS

Elevation drawings are a straight on view of each wall, with all the features measured vertically and horizontally, placing them on the wall space. This helps your designer locate your new cabinets and appliances along your walls.

Start with the sink wall, go clockwise from there

Start measuring your room with the sink wall. Label this Wall A. Then go clockwise around your room, labeling the walls B, C, and D.

Draw a rough sketch

Start by drawing a rough sketch (or two!) of each wall on a separate sheet of paper.

Measure the width of the wall

Measure the full width of each wall, beginning in the left corner. Check the width at two locations, 6 inches above the finished floor and 6 inches below the ceiling. Use the smallest dimension.

Measure the height of the wall

Measure the full height of each wall, beginning in the left corner. Check the height at two other locations. Use the smallest dimension.

Locate the openings

Measure to the outside edge of the trim. Then measure from the outside trim edge to the next opening, or to the far wall. Follow the measuring tips on page 2 to capture all the important details about windows and doors.

Locate fixtures and utilities

Measure horizontally to the center of outlets, switches, water lines and other utilities. Also measure the distance of these items from the floor. If there are HVAC wall vents, mark their location and size. Follow the measuring tips on page 3 for accuracy.

Transfer measurements to grid

Transfer all of your measurements to the grid pages in this guide. Label your drawings Wall A, Wall B, Wall C and Wall D. Then begin the Floor Plan Drawing.

If your space is L-shaped or has a bump out area, you can still draw an elevation view straight on. Just use a vertical line to show where the wall comes forward.

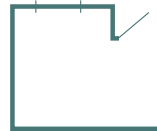

If your floor plan looks like this drawing...

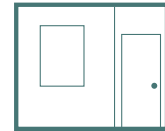

... your elevation view will look like this drawing.

ELEVATIONS: SINK WALL, WALL A

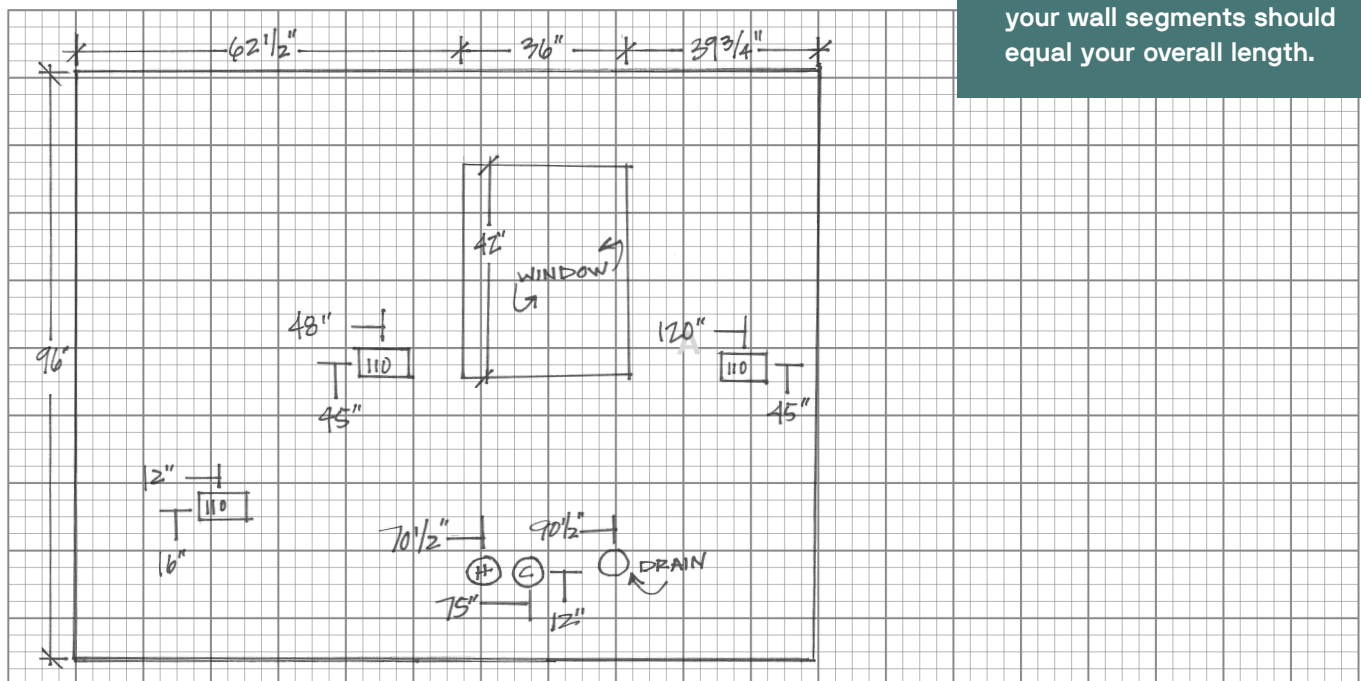

Always double-check your measurements! The total of your wall segments should equal your overall length.

Scale: 1/2" = 1'

3 CONSTRUCTION DETAILS

Doors and Openings

To make sure your new products fit through doorways into your space, record the actual openings for doors and hallways.

Entry Door: _____ inches

Interior Door 1: _____ inches

Interior Door 2: _____ inches

Hallway: _____ inches

Is there a basement or crawl space under the room that provides access to plumbing and heating ducts?

Yes No

Soffits

A soffit, also called a bulkhead, is a wall section that is built out at the ceiling level, usually in the area above wall cabinets.

Does the room have soffits?

Yes No

If yes, please fill out the two dimensions in the diagram to the right.

Do you plan to keep the existing soffits?

Yes No

Will the soffits have recessed lighting after the renovation?

Yes No

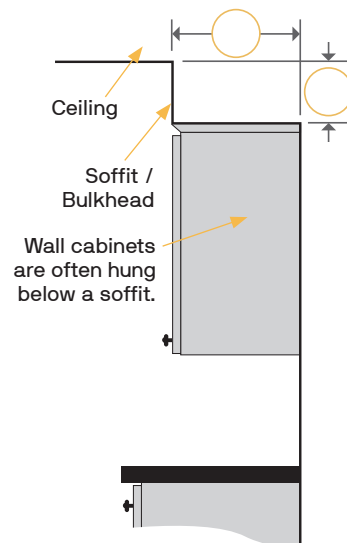

WARNING: Soffits typically contain electrical and plumbing elements that can't be relocated. Consult a professional on your remodel.

4 APPLIANCES

Appliance dimensions are critical to the overall fit of all kitchen components. Whether you are buying new appliances or using existing ones, provide the dimensions for each appliance in your kitchen. Door hinges and handles can obstruct surrounding cabinets and must be factored into

the design. Whenever possible, provide brand, model and spec sheets for appliances. Spec sheets are installation guides that list the dimensions of the appliance.

Please provide all appliance information.

	Existing	New	None	Brand	Model	Dimensions W x D x H	Spec Sheets Enclosed?
Sink	<input type="checkbox"/>	<input type="checkbox"/>	<input type="checkbox"/>			X X	<input type="checkbox"/> Yes <input type="checkbox"/> No
Disposal	<input type="checkbox"/>	<input type="checkbox"/>	<input type="checkbox"/>			X X	<input type="checkbox"/> Yes <input type="checkbox"/> No
Dishwasher	<input type="checkbox"/>	<input type="checkbox"/>	<input type="checkbox"/>			X X	<input type="checkbox"/> Yes <input type="checkbox"/> No
Compactor	<input type="checkbox"/>	<input type="checkbox"/>	<input type="checkbox"/>			X X	<input type="checkbox"/> Yes <input type="checkbox"/> No
Refrigerator	<input type="checkbox"/>	<input type="checkbox"/>	<input type="checkbox"/>			X X	<input type="checkbox"/> Yes <input type="checkbox"/> No
Freezer (stand alone)	<input type="checkbox"/>	<input type="checkbox"/>	<input type="checkbox"/>			X X	<input type="checkbox"/> Yes <input type="checkbox"/> No
Range	<input type="checkbox"/>	<input type="checkbox"/>	<input type="checkbox"/>			X X	<input type="checkbox"/> Yes <input type="checkbox"/> No
Cook Top	<input type="checkbox"/>	<input type="checkbox"/>	<input type="checkbox"/>			X X	<input type="checkbox"/> Yes <input type="checkbox"/> No
Exhaust Hood	<input type="checkbox"/>	<input type="checkbox"/>	<input type="checkbox"/>			X X	<input type="checkbox"/> Yes <input type="checkbox"/> No
Wall Oven	<input type="checkbox"/>	<input type="checkbox"/>	<input type="checkbox"/>			X X	<input type="checkbox"/> Yes <input type="checkbox"/> No
Microwave, wall mount	<input type="checkbox"/>	<input type="checkbox"/>	<input type="checkbox"/>			X X	<input type="checkbox"/> Yes <input type="checkbox"/> No
Microwave, countertop	<input type="checkbox"/>	<input type="checkbox"/>	<input type="checkbox"/>			X X	<input type="checkbox"/> Yes <input type="checkbox"/> No
Other:	<input type="checkbox"/>	<input type="checkbox"/>	<input type="checkbox"/>			X X	<input type="checkbox"/> Yes <input type="checkbox"/> No
Other:	<input type="checkbox"/>	<input type="checkbox"/>	<input type="checkbox"/>			X X	<input type="checkbox"/> Yes <input type="checkbox"/> No

5 PHOTOGRAPHY



Take photos of your space and share them with your Kitchen Designer. Label your shots to match your walls: A, B, C, D

- Straight on views of each wall: A (the sink wall), B, C, D (go clockwise around the room.)
- Photos of soffits or other construction details
- Close ups of anything unusual in your space: air vents, plumbing or gas lines, entrances or access notes.

WALL ELEVATION DRAWING

See instructions on page 5.

Materials List:

Before you begin measuring your space, make sure you have all the tools you need on hand.

- Tape measure (25' to ensure accuracy)
- Pencil with eraser
- Scrap paper
- Ruler or straight edge
- Step ladder
- Digital camera

Recommended:



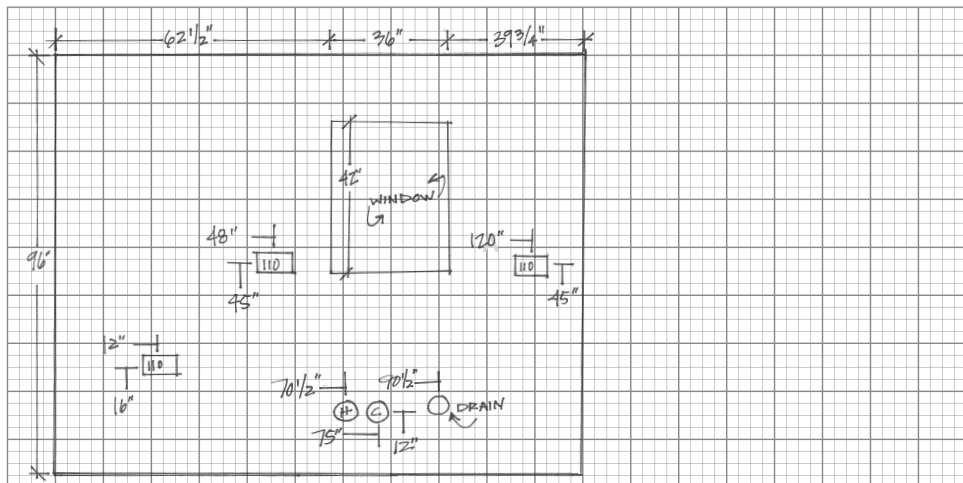

- Assistant
- Digital measuring tool

ELEVATIONS: SINK WALL, WALL A

Scale: 1/2" = 1'



Be Sure To Include These Items On Your Drawing

- Wall lengths and heights, $\pm 159''$ and wall segment lengths (the space between items)
- Width and height for doors & windows, including the frames (see tips on page 3)
- Water Lines & Drains ▲
- Gas Lines **G**
- 220 Volt Electrical Outlets 
- 110 Volt Electrical Outlets 
- Switches, Phone, TV   

How To Indicate Location Of Electrical Outlets And Switches

Indicates 16" from wall to center of outlet. (Measured from the left side, reverse if measuring from the right)

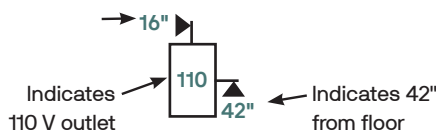

Door Swing

Show if the door opens in or out of the room, swings to the left or the right side.



Note:

Keep in mind that each large square equals one foot and each small square equals 3 inches. The scale of this grid is 3/4" = 1'













IMPORTANT:

Some cabinets or appliances may not fit through an existing doorway. Make sure you measure the width of all doorway openings on this floor plan drawing.

FLOOR PLAN

See instructions on page 4.

Be sure to include these items on your drawing, using these symbols:

- Wall Lengths $\pm 159''$
- Window & Door Openings  
- Water Lines ▲
- Drain Lines 
- Heating Ventilation and Air Conditioning (HVAC) Vents 
- 110 Volt Electrical Outlets 
- 220 Volt Electrical Outlets 
- Ceiling Light Locations 
- Wall Light Locations 
- Thermostat 
- Switches, Phone and TV   
- Gas Line **G**
- Range Hood 

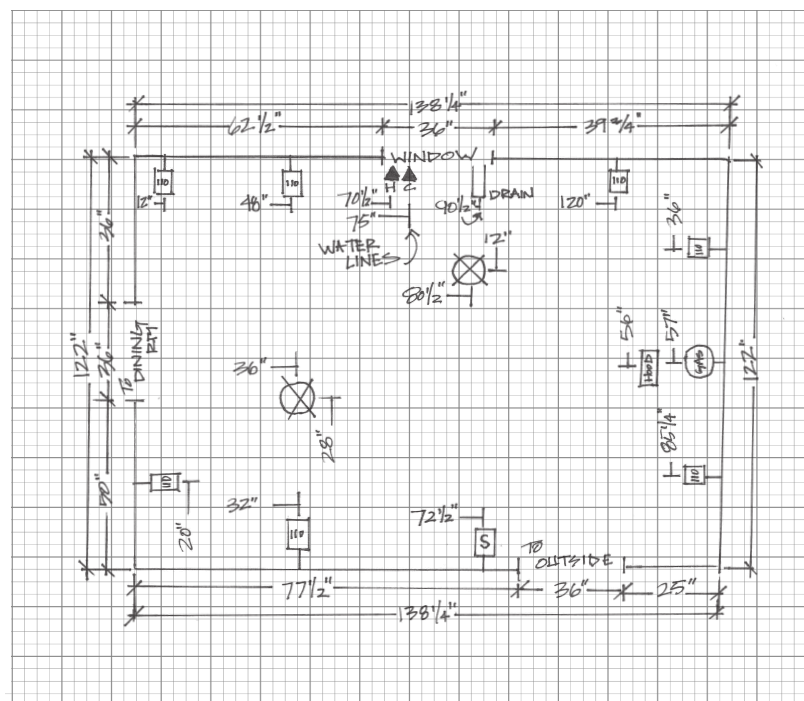

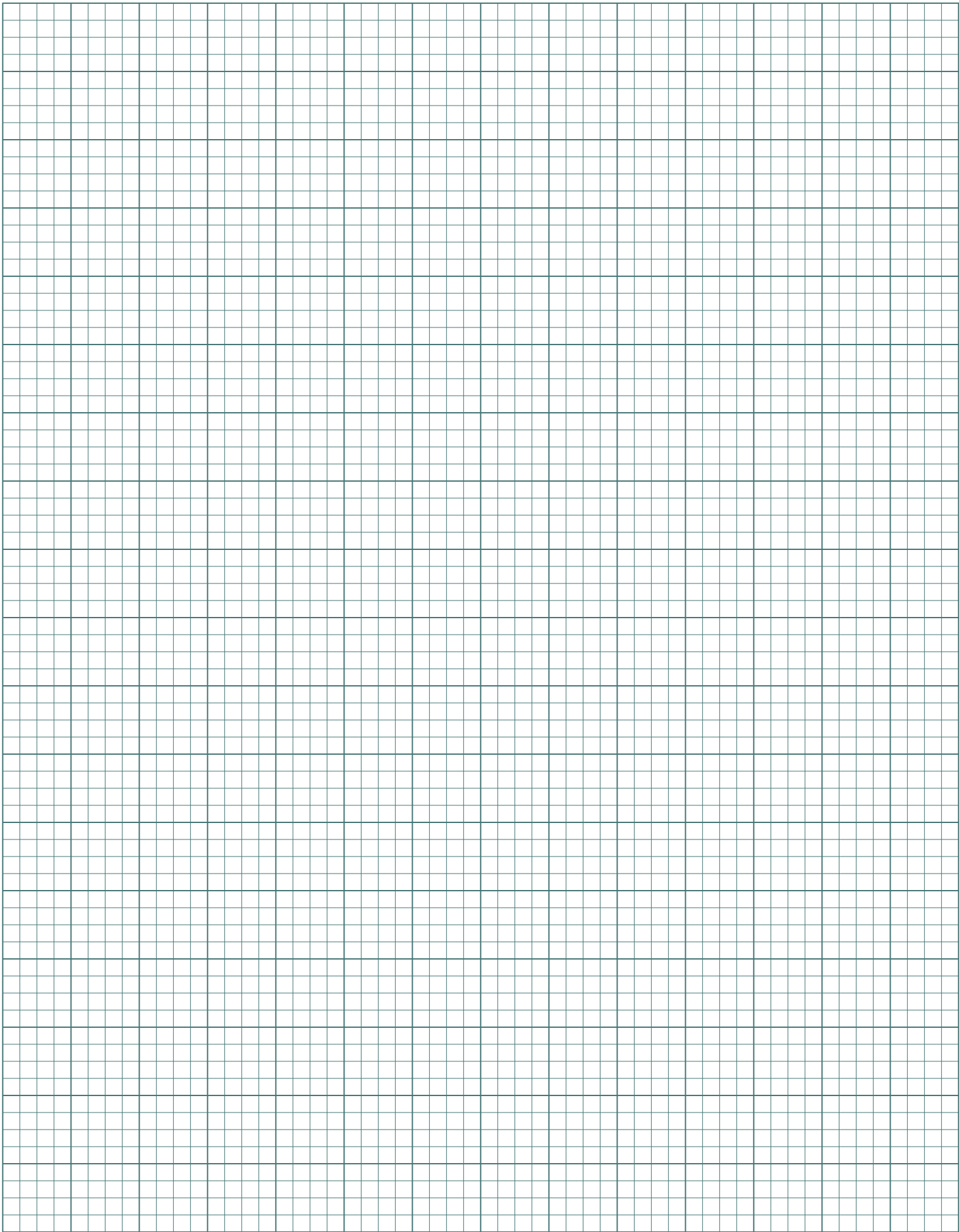

ELEVATIONS: SINK WALL, WALL A

Scale: 1/2" = 1'

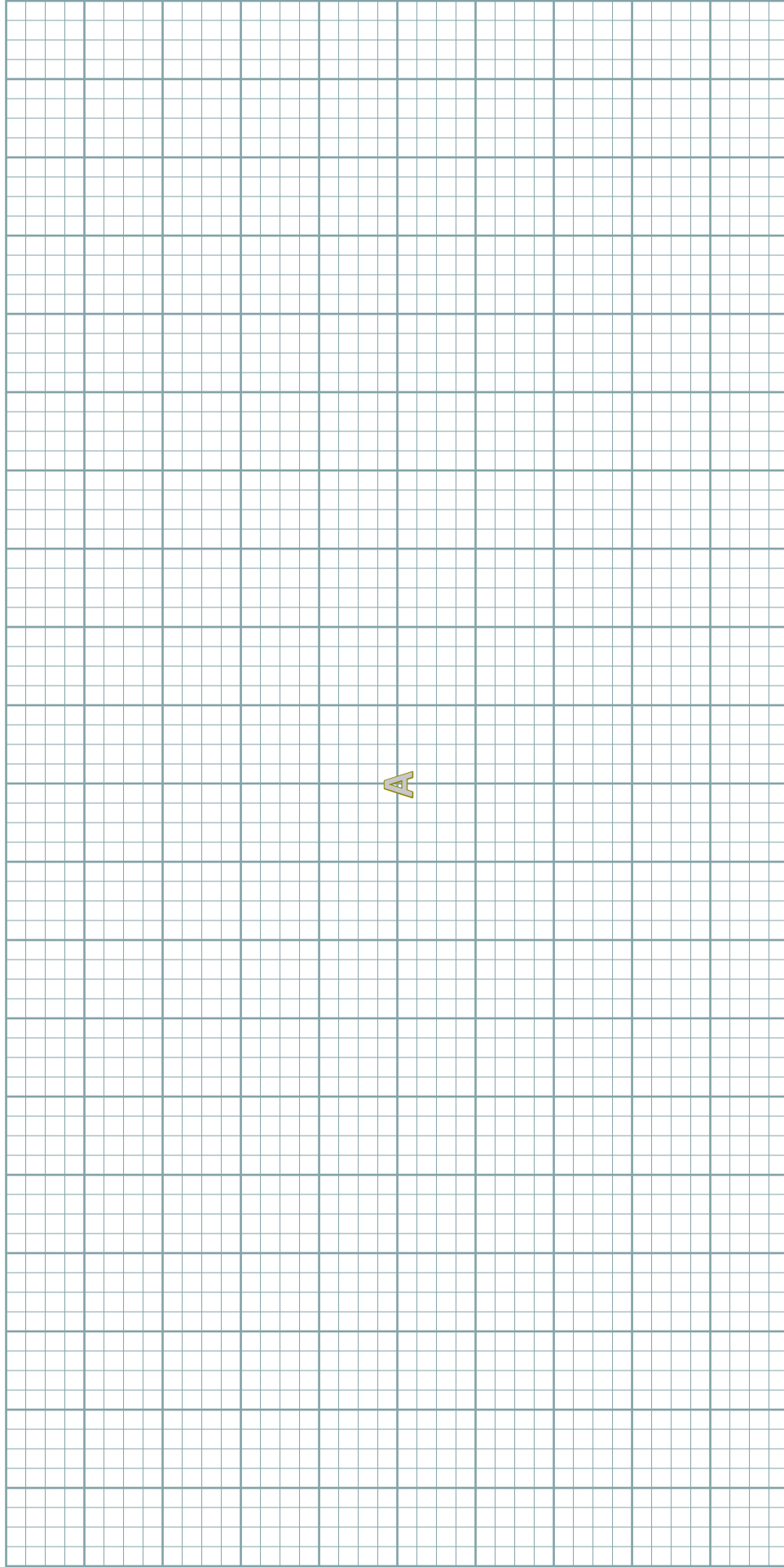

A

ELEVATIONS: SINK WALL, WALL B

Scale: 1/2" = 1'

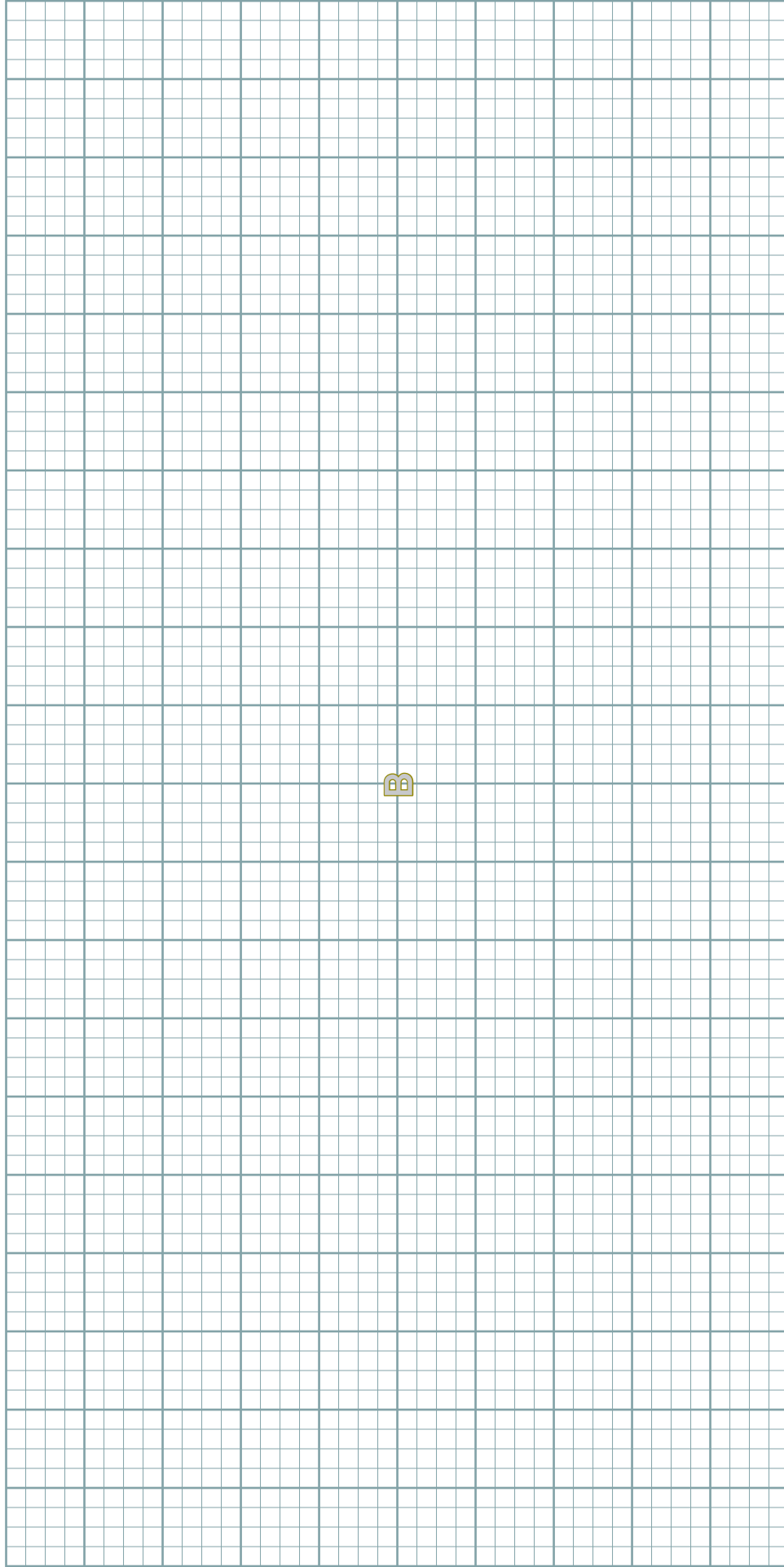

ELEVATIONS: SINK WALL, WALL C

Scale: 1/2" = 1'

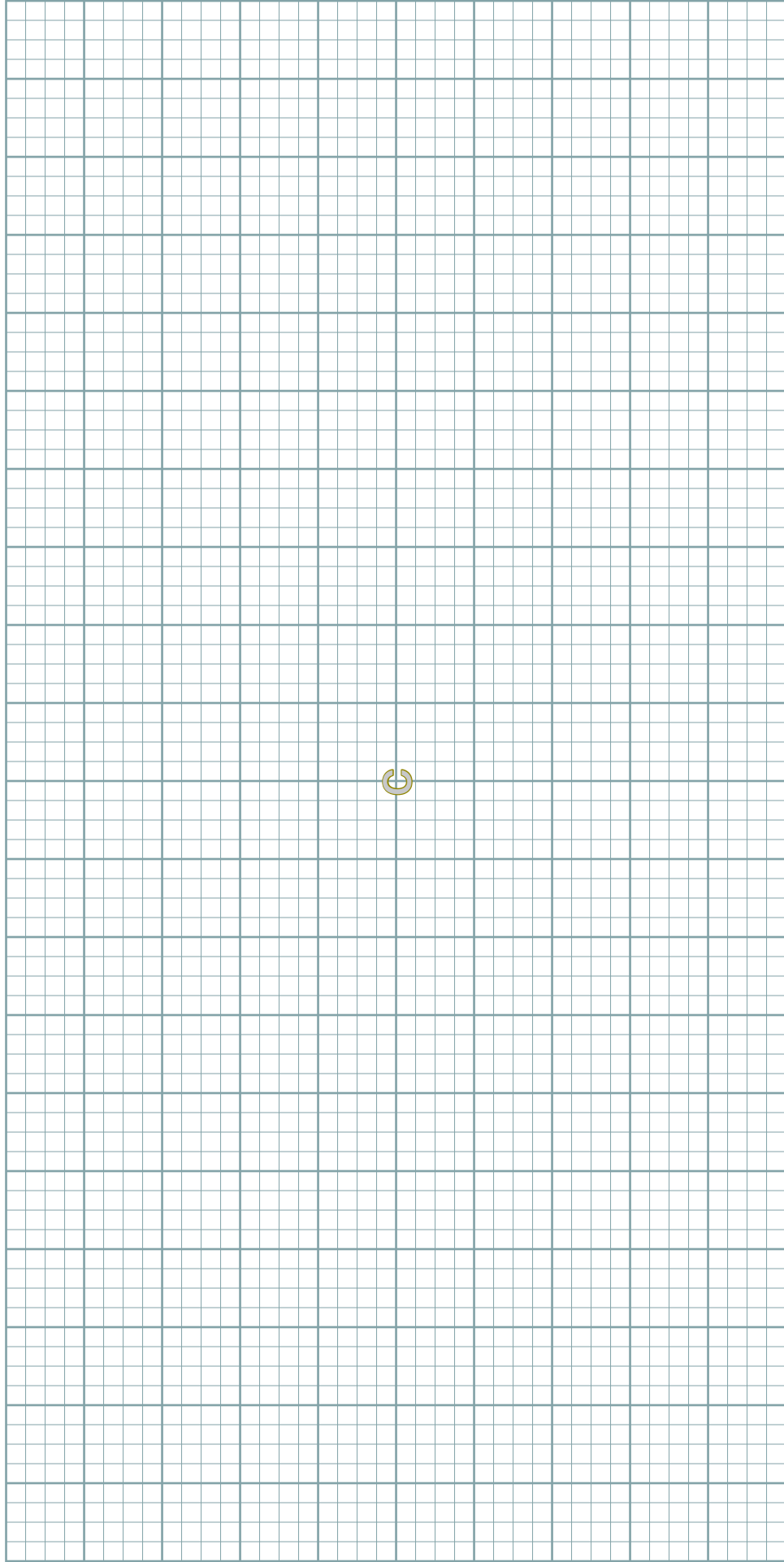

ELEVATIONS: SINK WALL, WALL D

Scale: 1/2" = 1'

